

Marian KUZMA¹

ASPECT'S EXPERIMENT AND THE NOBEL PRIZE IN PHYSICS 2022

The Aspect's experiment outcome is the key evidence to demonstrate the violation of Bell's inequalities. The experiment in question was performed by A. Aspect and his co-workers in three variations. In the paper herein, the third variation of the experiment, where a light switch was used to change polarisation of photons, is to be described. Switching the beam of photons was based on the Bragg diffraction phenomenon on ultrasound waves. An experimental proof of the violation of the Bell's inequalities has a crucial value in solving the Einstein - Bohr dispute on the nature of light. The Aspect's experiment and other papers on entangled states were honoured by being awarded the Nobel Prize in Physics in 2022 for Alain Aspect, John F. Clauser and Anton Zeilinger.

Key words: violation of Bell's inequalities, Bragg diffraction on standing waves.

1. INTRODUCTION

Lucjan Piela starts his excellent book on quantum mechanics in Chemistry [1] with the following, truly concerning issues:

- How to break the Heisenberg's Uncertainty Principle?
- Is the world real?
- Bell's inequalities shall decide...
- An intriguing result of experiments with photons,
- Teleportation.

The above-mentioned dilemmas were formulated at the very beginning of the quantum mechanics existence (100 years ago), and are subject to intense studies, both theoretical and experimental. It has all started with a thought experiment of Albert Einstein, Boris Podolsky and Nathan Rosen. It was the renowned EPR paradox [2]. It was in this experiment where the Heisenberg's Uncertainty Principle was challenged. At that time, Heisenberg's Uncertainty Principle was justified by Niels Bohr, who stated that all measurements influence a state of a system as a whole, regardless of distances among parts to which the system is disintegrated.

¹ Author for correspondence: Marian Kuzma, State Academy of Applied Sciences in Przemyśl, Książąt Lubomirskich 6, 37-700 Przemyśl, Poland. Phone: +48 500 456 246, e-mail: mkuzma@ur.edu.pl

Meaning, once an AB system is broken apart, the state of this system is an entangled state of particles A and B.

In 1964, John Bell [3,4] conducted an ‘experiment’ on passage of two spin polarized particles flowing in opposite directions and measured their spin polarisation while particles were in a certain distance from each other (regardless of how far). A thesis was that a polarisation measurement of one particle being in point A, does not influence polarisation of the second particle being in point B. Bell proved this thesis and it was represented in the famous Bell’s inequality.

$$N(2\alpha) \leq 2N(\alpha), \quad (1)$$

where α is an angle between polarizers, and $N(\alpha)$ is a number of discrepancy of measurement at the angle α .

An exceptionally straightforward interpretation of this inequality can be found in [1], (see page 40).

Lucjan Piela [1] gives reasons to the importance of this inequality by stating that such inequality ‘opens the gate to solve experimentally’ the dispute between:

1. Einstein, who claimed that particles are material and possess real properties regardless of the fact whether they are measured (observed) or not. It is a real world.

2. Bohr, who claimed that particles do not possess any specific properties before being measured (observed), and they update those properties only after their measurement, i.e. observation – it is an unreal world.

2. ASPECT’S EXPERIMENT

Bell’s inequality is difficult to disprove. However, it was just in 1981 that A. Aspect, P. Grangier, G. Roger [5,6] led an experiment where a correlation of polarised photons was tested. The result of the measurements was compliant with the quantum theory and was in clear contradiction with the Bell’s inequalities. A. Aspect, J. Dalibar and G. Roger [7] repeated the experiment in an improved version and proved violation of the Bell’s inequalities. Excited calcium atoms were the source of photons

2.1. The Idea Behind Aspect’s Experiment

The idea behind Aspect’s experiment is presented in Fig. 1 [8]. Two photons v_1 and v_2 , flow in opposite directions and hit polarizers, which can be oriented within xy plane, that is a plane perpendicular to photons trajectory. Each polariser has two output channels: channel + for photons with polarisation concordant with the polariser polarisation plane, and channel – for photons with polarisation perpendicular to the polarisation plane. Since photons are not polarised due to polarisers settings, they are directed to correct channels with a certain probability.

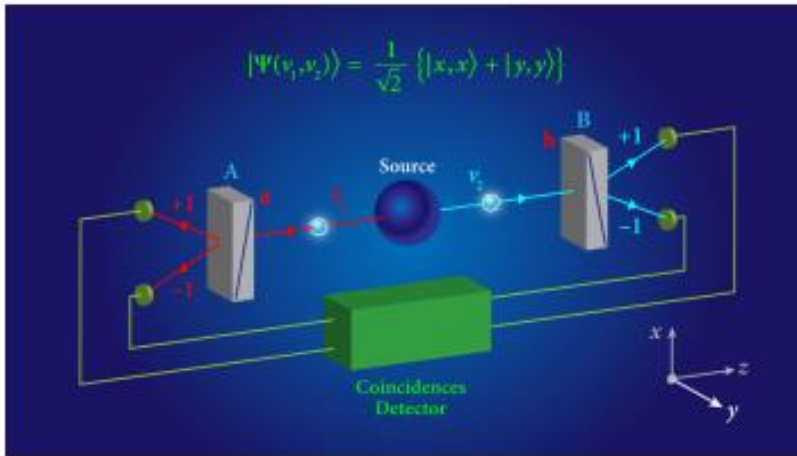

Fig. 1. A scheme of Aspect equipment derived from his original paper (Aspect, A.: Closing the Door on Einstein and Bohr's Quantum Debate. Physics 8, 123 (2015).

A quantum status of a system of two photons leaving the photon source is the entangled state:

$$\Psi(x, y) = 2^{-1/2} [|x, x\rangle + |y, y\rangle] \quad (2)$$

In the case of two entangled photons, random results, with a 50% probability, shall be obtained for channels + or - on both sides of the source. The entanglement enforces a strict correlation between those results. For example, if both polarizers are set in exactly the same position, the result on both sides will be either (++) or (--), but never (+-) or (-+). In the case of a random setting of polarizers against each other, correlations are neither strong enough nor limited by Bell's inequality (1). A degree of correlation of polarization is then measured by a correlation meter. From the Bell's inequality, which is true for local realism, it results that polarization measurement for photons on the right side does not influence the polarization measurement on the left side. Hence, if the right polarizer is rotated really fast, the correlation in the flow time for a given pair should be exactly the same as if the polarizer is not rotated at all. However, it is not the case in the experiment.

2.2. Aspect's Third Experiment

A. Aspect and his co-workers performed three experiments connected with violation of Bell's inequalities. The first of the experiments was described in paper [5], second in paper [6] and third in paper [7].

In the paper herein, the third experiment shall be described as being the most precise.

In the experiment in question, two identical optoacoustic switches for adjusting the frequency of switching the light were used and placed on both tracks where photons travelled: right (track b) and left (track a). The whole system was equipped with four polarizers and two light switches (see Fig. 2). The switches were supposed to direct photons to ancillary tracks (marked as ‘prim’ in Fig. 2), where polarizers and photomultipliers were placed as well. However, polarizers were polarized in a different way to those placed on the main track. The operation of switches was not correlated, still periodic, the switching time was 10 ns and it was far shorter than the time of flow of photons from the source to photomultipliers.

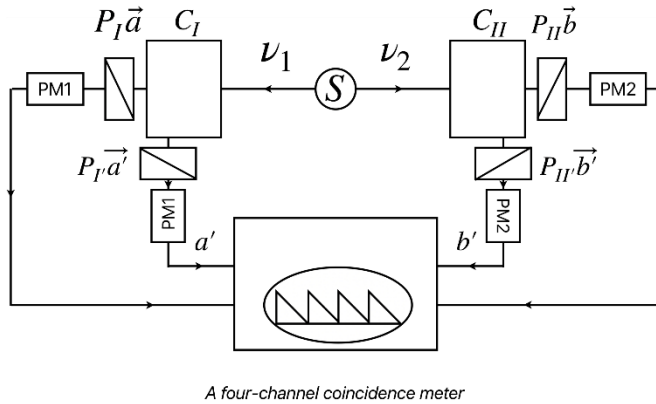

Fig. 2. A scheme of apparatus for Aspect's experiment with light switches [7]. C_I , C_{II} – light switches, PM 1, PM1', PM2, PM2' – photomultipliers, P_I , P_I' , P_{II} , P_{II}' – polarizers

Only pairs of entangled photons $\lambda_1 = 422.7$ nm and $\lambda_2 = 551.3$ nm, created as a result of a two-photon excitation of the calcium atoms [9], were tested. The photons were polarized in the same way on the plane perpendicular to the track axle and sent in two opposite directions I and II. The photons were falling on the two polarizers placed at a distance of 6 m from the source (see Fig. 2). Optoacoustic switches were placed on the path where photons were run and their task was to change a constant stream of photons to impulses of photons running every 20 ns. The beam was split up by the switch to two auxiliary ‘prim’ beams, running through auxiliary polarizers, which were needed to test polarization rate of photons by a four-channel coincidence meter. Polarizers could be rotated in a plane perpendicular to photons path. While polarizers were in parallel orientation, there was a complete correlation of polarizations of photons measured after their passage through polarizers. However, at polarizers rotating against each other at a certain angle, the results of the experiments were denoting that despite the polarizations of photons flowing in opposite directions were correlated after leaving the source, it was not known what polarization was on the way between the source and the polarizer. It was only after a measurement on the polarizer was made, e.g.

on PI polarizer, that this polarization was set, and thus, the polarization of the photon flowing in the opposite direction was set automatically. The Bell's inequality was checked for its form similar to the Clauser-Horne-Shimony-Holt inequality [10]:

$$-1 \leq S \leq 0 \quad (3)$$

where

$$S = N(a, b) / N(\infty, \infty) - N(a, b') / N(\infty, \infty') + N(a', b) / N(\infty', \infty) + N(a', b') / N(\infty', \infty') - N(a', \infty) / N(\infty', \infty) - N(\infty, b) / N(\infty, \infty), \quad (4)$$

The values $N(i, j)$, $i = a, a', j = b, b'$ are rates of calculating coincidences (i, j); $N(\infty, \infty)$ is a value of calculating coincidences with all polarisers being removed, $N(\infty', \infty)$, $N(\infty, \infty')$ are values of calculating coincidences with all polarisers on the right or left tracks and on proper prime tracks being removed, $N(a', \infty)$, $N(\infty, b)$ are values of calculating coincidences with polarisers on right or left tracks being removed.

3. AN OPTOACOUSTIC LIGHT SWITCH

The phenomenon of Bragg diffraction on a standing ultrasound wave in water was used by Aspect in his work [7], where he used it as a light switch. This effect is currently tested in many student Laboratories of Physics (Fig. 3).

The ultrasonic standing wave in water is induced by an ultrasonic head entered into water. The surface of the head is oriented in a direction parallel to the tank bottom with highest precision. By doing so, the incident wave and the wave reflected from the bottom shall create a standing wave. The condition for creating the standing wave is to adjust the distance between the head and the tank bottom precisely so that it equals a half of the wave length. To meet that condition, the tank is placed on a table with a precise slide and the table position is measured using a micrometer. The standing wave in fluid is a collective of fluid layers having a different pressure or density. Figure 4 shows the changes in fluid density being dependent on the x position and for the chosen time periods: $t=0$, $t = 1/8 T$, $t = 1/4 T$, $t = 3/8 T$, $t = 1/2 T$, $t = 5/8 T$, $t = 2/4 T$ and $t = 7/8 T$.

a)



b)

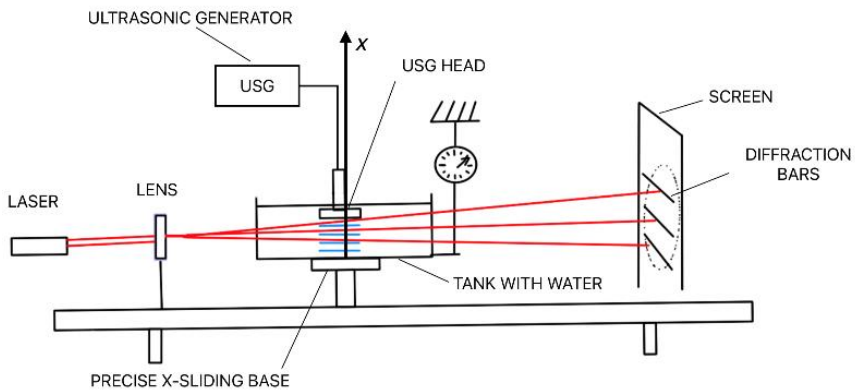

Fig. 3. The experiment of Bragg diffraction on ultrasonic waves in Laboratory of Physics of State Academy of Applied Science in Przemyśl (a). The scheme of the experiment (b)

Maximum fluid density is obtained for arrows, that is $x = \frac{1}{4} \lambda$ and $x = \frac{3}{4} \lambda$, etc. Layers of the condensed fluid are not observed for nodes. Light flows freely through those points. An image of a laser beam in a form of a red glow is observed on the screen. Such an image is obtained periodically at $T' = T/2$. It is the main beam in Aspect's experiment. For layers having a higher or lower density, the phenomenon of Bragg diffraction is received (Fig. 5), and stripes pulsating at $T' = -T/2$ period are observed on the screen. Pulsating of those stripes shall be, however, shifted in phase in regard to pulsation of the background. These pulsations are invisible to the naked eye for ultrasounds.

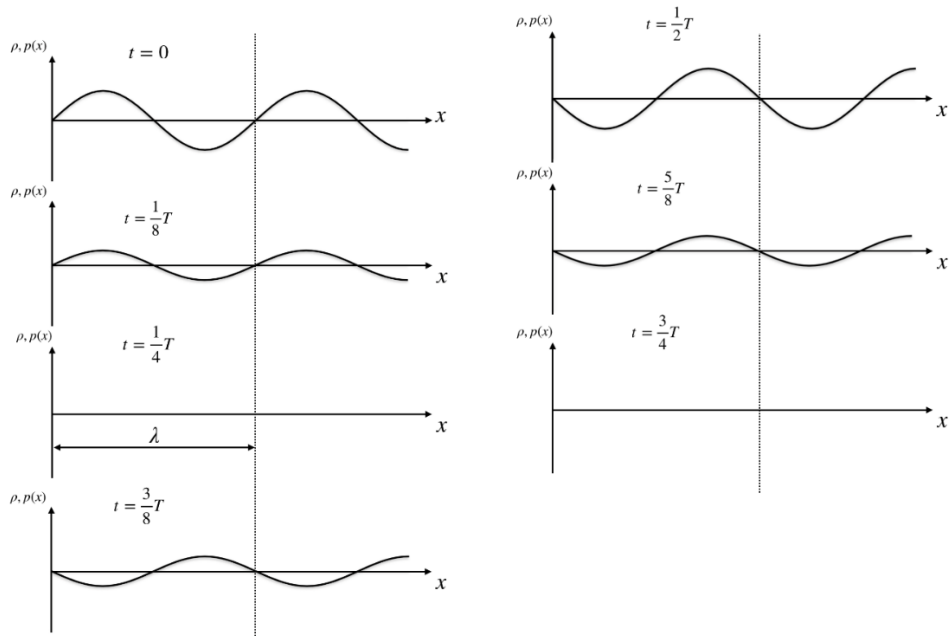
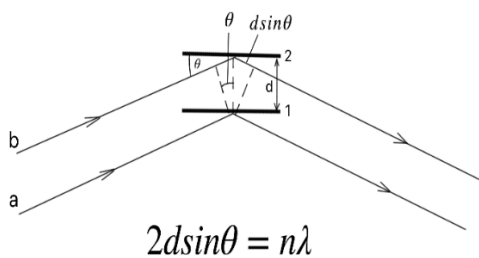

Fig. 4. The dependence of fluid density or pressure on a variable x in the standing wave for the chosen time periods t (T is a phase period)

a)



b)

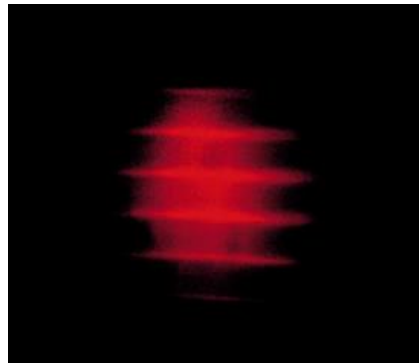

Fig. 5. A scheme of Bragg diffraction on an ultrasound standing wave (a); A diffraction image for the experiment with diffraction on the ultrasound standing wave in water (b) [11]

The Bragg beam served as an auxiliary beam in the Aspect's experiment. The main beam is subdued when the Bragg beam is at its maximum. This phenomenon serves as the light switch. The frequency of switching can be changed using the frequency of the ultrasonic wave.

4. RESULTS OF THE ASPECT'S EXPERIMENT

In the Aspect's experiment [7], the frequency of ultrasounds equals 20 MHz, thus the switching time is 10 ns. This time was far shorter than the time of the photon needed to move from the source to the polariser $L/2c = 20$ ns. The Bragg's angle equals $\Theta = 5 \times 10^{-3}$ rad. The $60\,000 \times 10^6$ pairs of photons coming out from the source within 3.3 hours were examined. This time was divided into three periods, 4000 s each. In the first time period, coincidences were measured using four polarizers of a set orientation. Then, in the second phase of the experiment, all polarizers were removed. In the third phase, one polarizer on each side was removed. The results were being recorded every 400 s in each phase. Mutual setting of polarizers was adjusted in such a way that a maximum deviation from the Bell's inequalities was obtained. The angles between polarisers were as follows [5]:

$$(a, b) = (b, a') = (a', b') = 22.5^\circ ; (a, b') = 67.5^\circ \quad (5)$$

At such settings, the S value was:

$$S_{\text{exp}} = 0.101 \pm 0.020 \quad (6)$$

Quantum mechanical calculations of the correlation for the above-mentioned angles equal $S_{\text{QM}} = 0.112$.

A statistic evaluation of the results gave a standard deviation of 0.020.

Hence, violation of Bell's inequalities ($S \leq 0$) equals to 5 standard violations.

It is reported in other papers on breaching the Bell's inequalities that a ratio of the result obtained experimentally to the standard violation is much higher. For instance, in paper [12], the result $S = 2.73 \pm 0.02$ was obtained.

5. CONCLUSIONS AND FINAL REMARKS

If polarization was changed just after the first photon left, the second photon would already know which polarization it needs to have on the point of the measurement for the first photon. How is that possible? It was moving in the opposite direction, was at a distance of a few meters from the first one, no information could have reached it as switching polarizer A lasted 10 nanoseconds, thus information about switching would have to reach the second photon at a speed greater than the speed of light. It remains a mystery to physicists: what transfer of information can be faster than the transfer at the speed of light?



Fig. 6. The Nobel Prize winners in Physics in 2022.
Alain Aspect, John F. Clauser, Anton Zeilinger

Aspect, the author of the experiment, and the authors of later papers on entangled states, were awarded the Nobel Prize in Physics in 2022 (Fig. 6) – (“for experiments with entangled photons, establishing the violation of Bell inequalities and pioneering quantum information science”).

It is worth noticing that the works of Aspect, Clauser and Zeilinger contributed to a new area of physics being created in the nineties of the previous century, namely Quantum Computing and Quantum Cryptography.

REFERENCES

- [1] Piela L., *Idee Chemii Kwantowej*, Wydawnictwo Naukowe PWN, Warszawa 2006 (in Polish).
- [2] Einstein A., Podolsky B., Rosen N.: *Can quantum-mechanical description of physical reality be considered complete?*, Phys. Rev. 47, 1935, s. 777-780 .
- [3] Bell J.S., *On the Einstein Podolsky Rosen paradox.*, Physics 1, 1964, s. 195-200
- [4] Bell J.S.: *On the problem of hidden variables in quantum mechanics*. Rev. Mod. Phys. 38(3), 1966, s. 447-452.
- [5] Aspect A., Grangier, P., Roger, G.: *Experimental tests of realistic local theories via Bell's theorem*. Phys. Rev. Lett. 47(7), 1981, s.460-463.
- [6] Aspect A., Grangier P., Roger G.: *Experimental realization of Einstein-PodolskyRosen-Bohm Gedankenexperiment – a new violation of Bell inequalities*. Phys. Rev. Lett. 49(2), 1982, s. 91-94.
- [7] Aspect A., Dalibard J., Roger G.: *Experimental test of Bell inequalities using time-varying analyzers*. Phys. Rev. Lett. 49(25), 1982, s. 1804-1807.
- [8] Aspect A., *Closing the Door on Einstein and Bohr's Quantum Debate*. Physics 8, 2015, s. 123-128.
- [9] Aspect A., Imbert C., Roger G., *Absolute measurement of an atomic cascade rate using a two photon coincidence technique*. Application to the 4p21S0-4s4p 1P1 - 4s21S0 cascade of calcium excited by a two photon absorption Optics Communications 34, 1980, s. 46-52.
- [10] Clauser J.F., Horne, M.A., Shimony A., Holt R.A.: *Proposed experiment to test local hidden variable theories*. Phys. Rev. Lett. 23(15), 880-884 (1969).
- [11] Laboratory Experiments, Optical determination of velocity of sound in liquid, LEP 1.5.10. , PHYWE SYSEM GMBH.

- [12] Weihs G., Jennewein T., Simon C, Weinfurter H., and Zeilinger A., *Violation of Bell's Inequality under Strict Einstein Locality Conditions*, Phys.Rev. Lett.81, 1998, s. 5039-5043.

DOŚWIADCZENIE ASPECTA I NOBEL Z FIZYKI 2022

Streszczenie. Wynik doświadczenia Aspecta jest kluczowym dowodem na naruszenie nierówności Bella. Doświadczenie to, A. Aspect z współpracownikami wykonali w trzech wariantach. W niniejszej pracy opisujemy trzeci wariant, w którym zastosowano przełącznik światła do zmiany polaryzacji fotonów. Przełączanie strumienia fotonów opierało się na zjawisku dyfrakcji Bragga na falach ultradźwiękowych. Doświadczalne potwierdzenie złamania nierówności Bella ma podstawowe znaczenie w rozwiązaniu sporu Einstein-Bohr na temat natury świata. Doświadczenie Aspecta i inne prace na temat stanów splątanych zostało uhonorowane przyznaniem nagrody Nobla z Fizyki w 2022 roku dla Alaina Aspecta, Johna F. Clausera i Antona Zeilingera.

Słowa kluczowe: Złamanie nierówności Bella, Dyfrakcja Bragga na falach stojących.

DOI: 10.7862/rf.2023.pfe.3

Received: dd.mm.2023

Accepted: dd.mm.2023

Published online: October 2023